



Grip TRAY TURNER

Patented System

The Grip Tray Turner is an all-round tray turner with a capacity of up to 100 trays per minute. It automatically turns any sealable tray from either short-side or long-side leading. The patented turning system ensures smooth and consistent performance, even at high speeds.

Gentle Handling

Complete tray turning control allows the device to gently rotate trays without affecting the product or its position inside the tray. This makes the Grip Tray Turner ideal for delicate products that must remain in place after denesting, sealing, or handling.

Flexible Integration

The Grip Tray Turner can be adjusted to fit different tray formats and includes automatic speed regulation from the denester. It comes with an integrated conveyor driven by a drum motor and frequency converter. The Grip Tray Turner can be used as a stand-alone unit or integrated with our systems such as the Step Loader or Easy Loader.

QUPAQ[®]
ANY FOOD IN ANY TRAY

Specifications

Grip Tray Turner

Capacity	Operational Temperature	Humidity	Weight	Steel Quality	IP Class
Up to 100 trays/min	5°-40° C	Min. 10% Max. 90%	Approx. 150 kg	EN 1.4301 AISI 304	*IP65

Noise Level	Power Supply	Power Consumption	Full-Load Current	Max SCCR (Ik Max)	Max Fuse	Frequency
< 80 dB	200-240V L1 + N (L1 + L2)	0.29 kW	1.26 A	6 kA	13 A	50 Hz

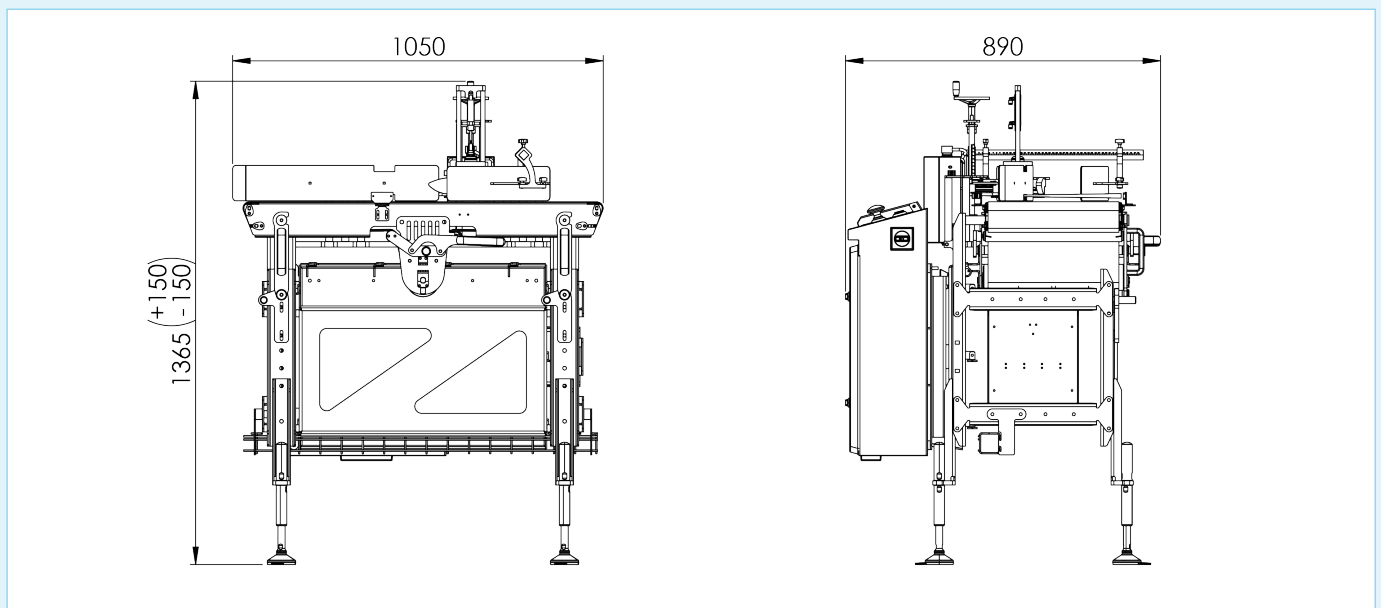

The illustrations and specifications are of the Grip Tray Turner.

Specifications and photos are intended as a guide and can be changed by QUPAQ without notice. We make reservations for misprints and typing errors.

*Although the IP rating stated in the table is IP65, the machine incorporates additional components with higher protection ratings, up to IP69K.