

Smart TOOL TWIN

Double Denesting Power

The Smart Tool Twin is designed for high-speed denesting with double-lane output. With a capacity of up to 2×200 trays per minute, it denests two rows of trays simultaneously, which makes it ideal for high-capacity production environments.

Fast Changeovers

A tool change and restarting production takes under a minute. This makes the Smart Tool Twin a game-changer for minimizing downtime and ensuring operational flow, even when handling multiple tray types across shifts or product lines.

Hygienic Design

The Smart Tool Twin is custom-built for perfect denesting of your specific tray. Its open, stainless-steel design is easy to clean and built to meet strict hygiene standards. It is your guarantee for fast, safe, and consistent tray handling in any production setup.

QUPAQ[®]
ANY FOOD IN ANY TRAY

Specifications

Smart Tool Twin

Capacity	Weight	Tray Dimensions
Up to 2×200 trays/min	Approx. 25 kg	Min. L: 95 mm Max LxW: 266×210 mm For ready meal trays: Min. center distance: W + 94 mm Max LxW: 215×155 mm

Noise Level	Steel Quality	Humidity	Operational Temperature
< 80 dB	EN 1.4301 AISI 304	Min. 10% Max. 90%	5°C - 40° C

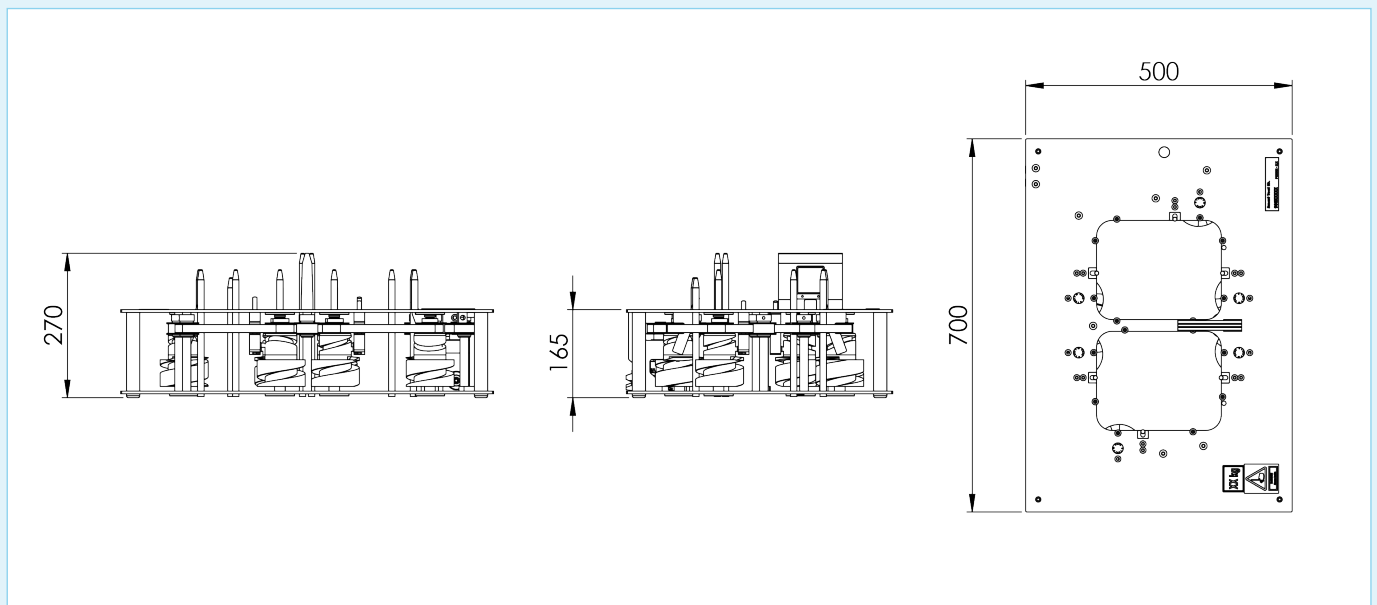

The illustrations and specifications are of the Smart Tool Twin.

Specifications and photos are intended as a guide and can be changed by QUPAQ without notice. We make reservations for misprints and typing errors.